

D Series – 16" & 22" Low Bay

Dimensions

Fixture	Length	Width	Ship Wt.
LDS Series	24"	16.6"	25 LBS. (APPROX.)
LDM Series	25.7"	22.4"	25 LBS. (APPROX.)

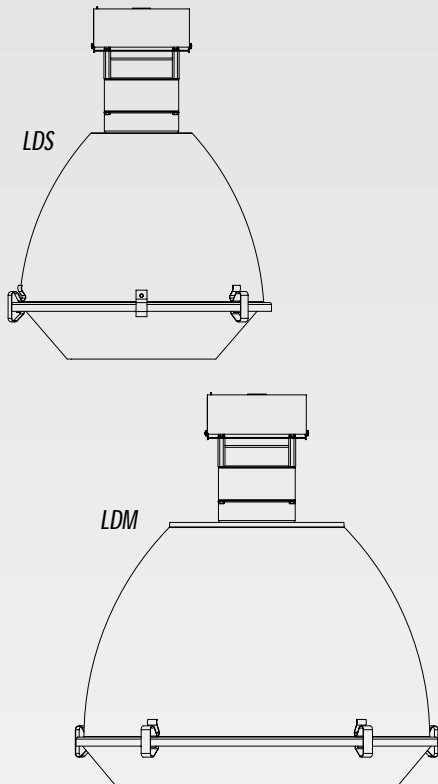

The LD Series Low Bay luminaires are perfect for both low cost commercial and industrial applications that require high light levels, good three dimensional visibility and a wide beam pattern at low mounting heights.

Optics

The drop lens assembly is easily snapped into place with clips and is hinged to provide tool-free lamp access. The refractor is made of color resistant virgin acrylic.

Ballast

The unique ballast mounting allows most of the heat to be generated into the air while the capacitor is housed in a separate compartment with an air barrier between the ballast and capacitor.

Lamps

The LD Series uses mogul base metal halide (250 & 400W), standard lamps.

Mountings

Two separate mounting options are available:

3/4" Conduit Mount

-Hook, Cord & Plug

Labels

The LD Series is UL listed for damp locations and comes standard as an enclosed luminaire.

Warranty

The LD Low Bays sold by C.E.W. Lighting, Inc., unless otherwise specified, will be warranted to be free of defects in materials and workmanship under normal use and service for a period of five (5) years from date of shipment. If found to be defective by us, we will replace the non-performing components.



40°C, 55°C Ambient Rated  LISTED FOR DAMP LOCATIONS
CONSULT FACTORY FOR CUL AVAILABILITY

I.E.S. photometrics available by e-mail or on disk.

16" Low Bay

Cat #: LDS0425, LDS2425
Lamp: 250W Clear MH
Lumens: 26,000
Certified Test Report: ITL45980
IES File: LBS425.IES
Spacing Criteria: 1.5

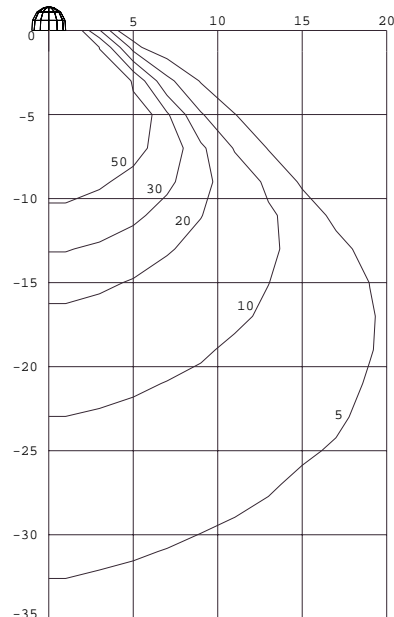

22" Low Bay

Cat #: LDM0440, LDM2440
Lamp: 400W Clear MH
Lumens: 38,000
Certified Test Report: ITL45177
IES File: LBM440SE.IES
Spacing Criteria: 1.8

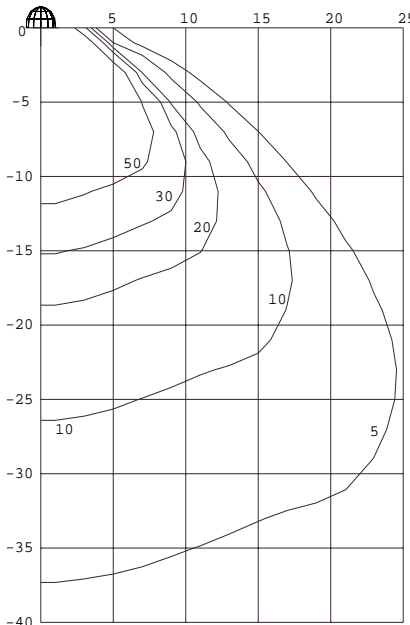

LD Series Ambient Temperature Ratings

Fixture	Enclosed Only	
	40°C	55°C
250W	yes	LDM only
320W	yes	no
350W	yes	no
400W	yes	no



To build catalog numbers refer to inside front cover

D Series –16" & 22" Low Bay

Wattage Range:
250 & 400W

16" – LDS Series Order Information

Reflector Size	Wattage Lamp	Catalog Number	
		Conduit Mount	Hook, Cord & Plug
16"	250W MH	LDS0425-(a)(b)	LDS2425-(a)(b)
	400W MH*	LDS0440-(a)(b)	LDS2440-(a)(b)

22" – LDM Series Order Information

22"	250W MH	LDM0425-(a)(b)	LDM2425-(a)(b)
	400W MH	LDM0440-(a)(b)	LDM2440-(a)(b)

(a) Voltage Suffix Key: Indicate voltage in space (a)

Description					
120 Volt	277 Volt	208 Volt	240 Volt	480 Volt	Multi-tap
1	2	3	4	5	M
tapped @ 277V					

(b) Options: Indicate options in space (b) (Factory Installed)

Description	SUFFIX (b)
Coated Lamp	C

Accessories: (Field Installed)

Description	Catalog Number
Ballast/Reflector Safety Chain - 6'	SC-6
Hook Only	HKSC
Wire Guard - 22"	EB22WG

*Reduced Jacketed Lamp Required

Lamp Included



LDM
22" Spun
Aluminum
Reflector