

FSM Series Sign Light

Dimensions	Fixture Length	Fixture Depth	Approx. Ship Wt.
FSM Series	16.4" Sq.	7.0"	38lbs.

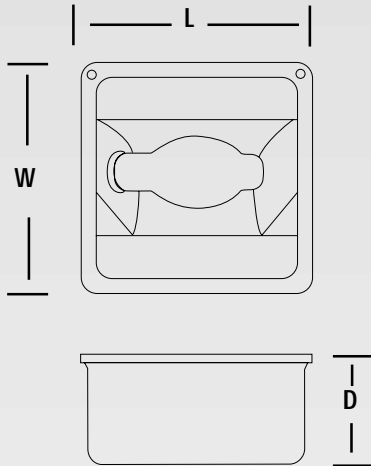

EPA Rating: Listed on page 34.

Housing

The sleek square 16" die cast aluminum housing with flush door frame and rounded edges are standard with bronze polyester powder top coat, other colors available on request (Consult Factory).

EPA Rating

Because of its unique design, lower EPA levels are obtained, resulting in lower pole costs.

Optics

This IES Type IV narrow cutoff luminaire, while minimizing spill light, is designed to illuminate signs or billboards.

Lens

A clear, tempered glass lens is held securely in a die cast door frame.

Ballast

All fixtures are standard with a high power factor multi-tap ballast (except 480V). All units are supplied with a 36" SOW16/3 cord connected to requested voltage. If no voltage is specified, cord is connected to 277V lead.

Gasketing

Complete silicone gasketing around lens frame and at mounting provide a watertight seal. It is recommended to have a minimum 1° tilt on luminaire face.

Lamps

The 16" housing utilize 175W-400W mogul base lamp.

Mounting Options

For complete descriptions of mounting options, please refer to pages 42-47.

Warranty

The FS Cutoff Floodlight sold by C.E.W. Lighting, Inc., unless otherwise specified, will be warranted to be free of defects in materials and workmanship under normal use and service for a period of five (5) years from date of shipment, 175W-1000W. Lower wattages will be warranted for (2) years. If found to be defective by us, we will replace the non-performing components.



55°C Ambient Rated



LISTED FOR WET LOCATIONS
CONSULT FACTORY FOR CUL AVAILABILITY

I.E.S. photometrics available by e-mail or on disk

16" Sign Light

Cat #: FSM3440
Lumens: 32,000
Mounting Distance: 5'
Certified Test Report: LTL06474
IES File: FSM440.IES
Tilt: 110°

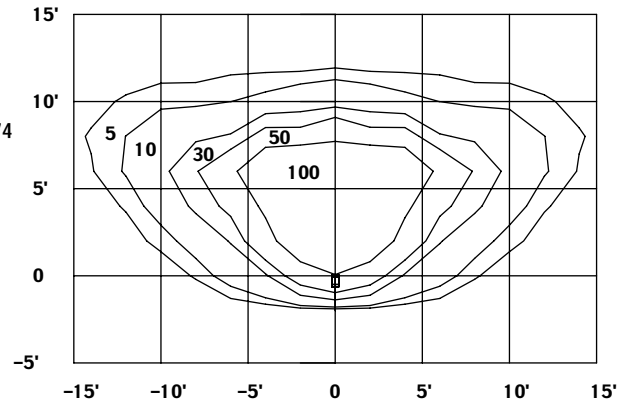



To build catalog numbers refer to inside front cover

Sign Light Order Information

Housing Size (sq.)	Wattage Lamp	Catalog Number (add mounting code)	Mounting Code (Insert Code at * in Cat. #)
16"	175W MH	FSM*417-(a)(b)	3 = 2" Adjustable Slip Fitter
	250W MH	FSM*425-(a)(b)	4 = Yoke Mt.
	400W MH	FSM*440-(a)(b)	8 = Without Mounting
	200W MH/PS	FSM*820-(a)(b)	
	250W MH/PS	FSM*825-(a)(b)	
320W MH/PS	FSM*832-(a)(b)		
350W MH/PS	FSM*835-(a)(b)		
400W MH/PS	FSM*840-(a)(b)		
16"	250W HPS	FSM*525-(a)(b)	
	400W HPS	FSM*540-(a)(b)	

LESS
LESS
LESS
LESS
LESS

(For wall mount brackets see page 47)

(a) Voltage Suffix Key: Indicate voltage in space (a)

Description	120 Volt	277 Volt	208 Volt	240 Volt	480 Volt	Multi-tap
	1	2	3	4	5	M
	tapped @ 277V					

(b) Options: Indicate options in space (b) (Factory Installed)

Description	SUFFIX (b)
Fusing	
Single (120V & 277V) <i>Specify Voltage in Suffix (a)</i>	F
Dual (208-240-480V) <i>Specify Voltage in Suffix (a)</i>	J
Quartz Standby (includes Q lamp: 150W Hot/Cold type.)	Q
Photo Control - <i>Specify Voltage in Suffix (a)</i>	P
A twist lock receptacle & matching photocell are supplied	
White Housing (Custom Colors Available: consult factory for pricing and delivery.)	WT
Black Housing (Custom Colors Available: consult factory for pricing and delivery.)	BK

Accessories: (Field-Installed)

Description	16" housing Catalog Number
Wire Guard	WG-16
Backlight Shield	BLS-16
Vandal Shield	VS-16

FSM Series Sign Light

Wattage Range:
175-400W



Lamp Included

Mountings

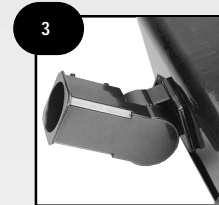

3 2" Adjustable Slip Fitter



4 Yoke Mount

8 Without Mounting
(Factory Drilled)