

FV Series - 23" Square Vertical Burn Luminaire

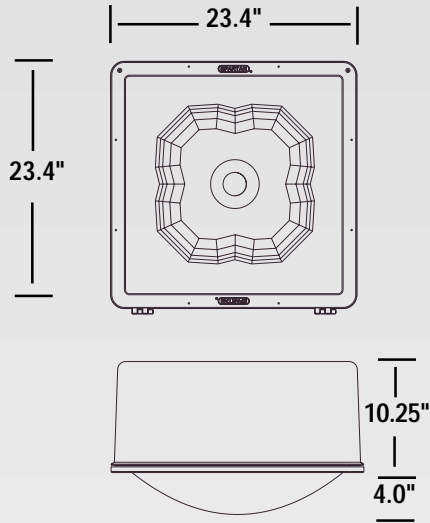

Dimensions	Fixture Length	Fixture Width	Fixture Depth	Approx. Ship Wt.
FVL Series	23.4"	23.4"	10.25"	80 lbs.



55°C Ambient Rated



LISTED FOR WET LOCATIONS
CONSULT FACTORY FOR CUL AVAILABILITY

I.E.S. photometrics available by e-mail or on disk

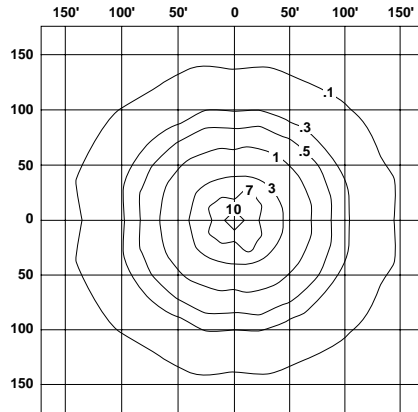

1000W MH Vertical Burn Luminaire at 30' mount height, 0° vertical tilt.

EPA Rating: Listed on page 34.

The low profile and compact size cast aluminum housing with rounded edges is the lowest EPA in the industry. Utilizing a specially designed segmented ultra bright anodized aluminum reflector; the vertical burn reduced jacket lamp provides a symmetrical Type 5 square pattern.

Housing

The fixture housing is 23" square by 10" deep with a 4" sag glass tempered lens. The housing is polyester powder coated bronze, black or white as standard. Other colors available on request (Consult Factory). The hinged door frame closes flush with the housing using 2 Stainless Steel screws.

Optics

Multifaceted ultra bright anodized segmented aluminum provides a Type V distribution pattern using a vertical burn lamp.

Lens

The fixture has a drop down hinged door frame containing a 4" sag glass lens.

Ballast

All fixtures are standard with a high power factor multi-tap ballast (except 480V). All units are supplied with a 36" SOW16/3 cord connected to requested voltage. If no voltage is specified, cord is connected to 277V lead.

Lamps

The compact sized housing allows for use of either metal halide or high pressure sodium mogul base lamps ranging in wattage from 320 to 1000W. Standard sized lamps are utilized through 400W. (Reduced jacket 750W & 1000W lamps are required).

Maintenance

The drop down hinged door provides easy access to the lamp and ballast chambers. Neoprene gasketing on the door frame seals out contaminants.

Warranty

The FV Vertical Burn Luminaire sold by C.E.W. Lighting, Inc., unless otherwise specified, will be warranted to be free of defects in materials and workmanship under normal use and service for a period of five (5) years from date of shipment. If found to be defective by us, we will replace the non-performing components.

To build catalog numbers refer to inside front cover

Vertical Burn Luminaire Order Information

Housing Size (sq.)	Wattage Lamp	Catalog Number (add mounting code)	Mounting Code (Insert Code at * in Cat. #)
ESS 23"	320W MH/PS	FVL*832-(a)(b)	2 = 6" Extended Pole Mt.
ESS	350W MH/PS	FVL*835-(a)(b)	5 = 12" Extended Pole Mt.
ESS	400W MH/PS	FVL*840-(a)(b)	8 = Without Mounting
	400W MH	FVL*440-(a)(b)	9 = Drill for Wishbone Mt.
ESS	750W MH/PS*	FVL*875-(a)(b)	(23" Housing Factory Drilled for Wishbone is Standard.)
	1000W MH*	FVL*499-(a)(b)	
	400W HPS	FVL*540-(a)(b)	
	600W HPS	FVL*560-(a)(b)	
	1000W HPS*	FVL*599-(a)(b)	

(a) Voltage Suffix Key: Indicate voltage in space (a)

Description	120 Volt	277 Volt	208 Volt	240 Volt	480 Volt	Multi-tap
	1	2	3	4	5	M
	tapped @ 277V					

(b) Options: Indicate options in space (b) (Factory Installed)

Description	SUFFIX (b)
Glare Shield	GSH-23
High-2-Low Option (16" & 23" Housing Only) (See Pgs. 28-29)	H
Photo Control (A twist lock receptacle and matching photocell are supplied.)	
Specify Voltage in Suffix (a)	P
White Housing (Custom Colors Available: Consult factory for pricing and delivery.)	WT
Black Housing (Custom Colors Available: Consult factory for pricing and delivery.)	BK
Wishbone Mt. for 4" Square Pole	WBS23 ^①
Wishbone Mt. for 4" Round Pole	WBR23 ^①

^① See page 30 – Tenon Adaptor for restrictions.

* Reduced jacketed lamps

FV Series - 23" Square Vertical Burn Luminaire

Wattage Range:
350-1000W



Lamp Included

Mountings

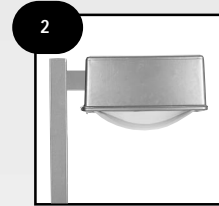

6" Extended Pole Mount

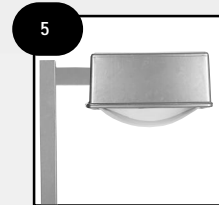

12" Extended Pole Mount



Wishbone Mount



Without Mounting
(Factory Drilled)

Options



GSH-23